

Konstruktionshinweise 1

Mischbauweise Vollholzkonstruktion und Mauerwerk

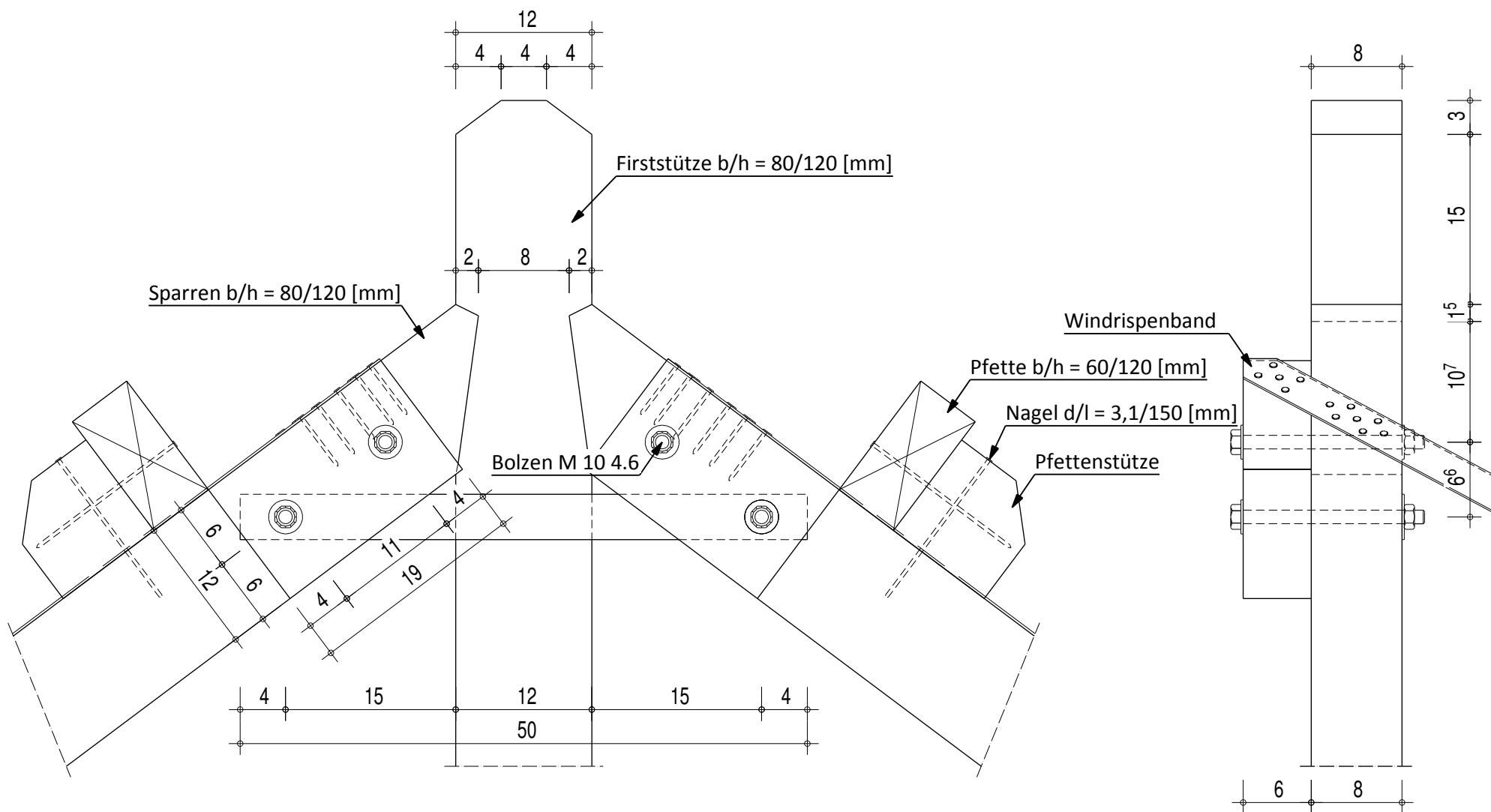

Kehlbalkenanschluss Maßstab 1: 5

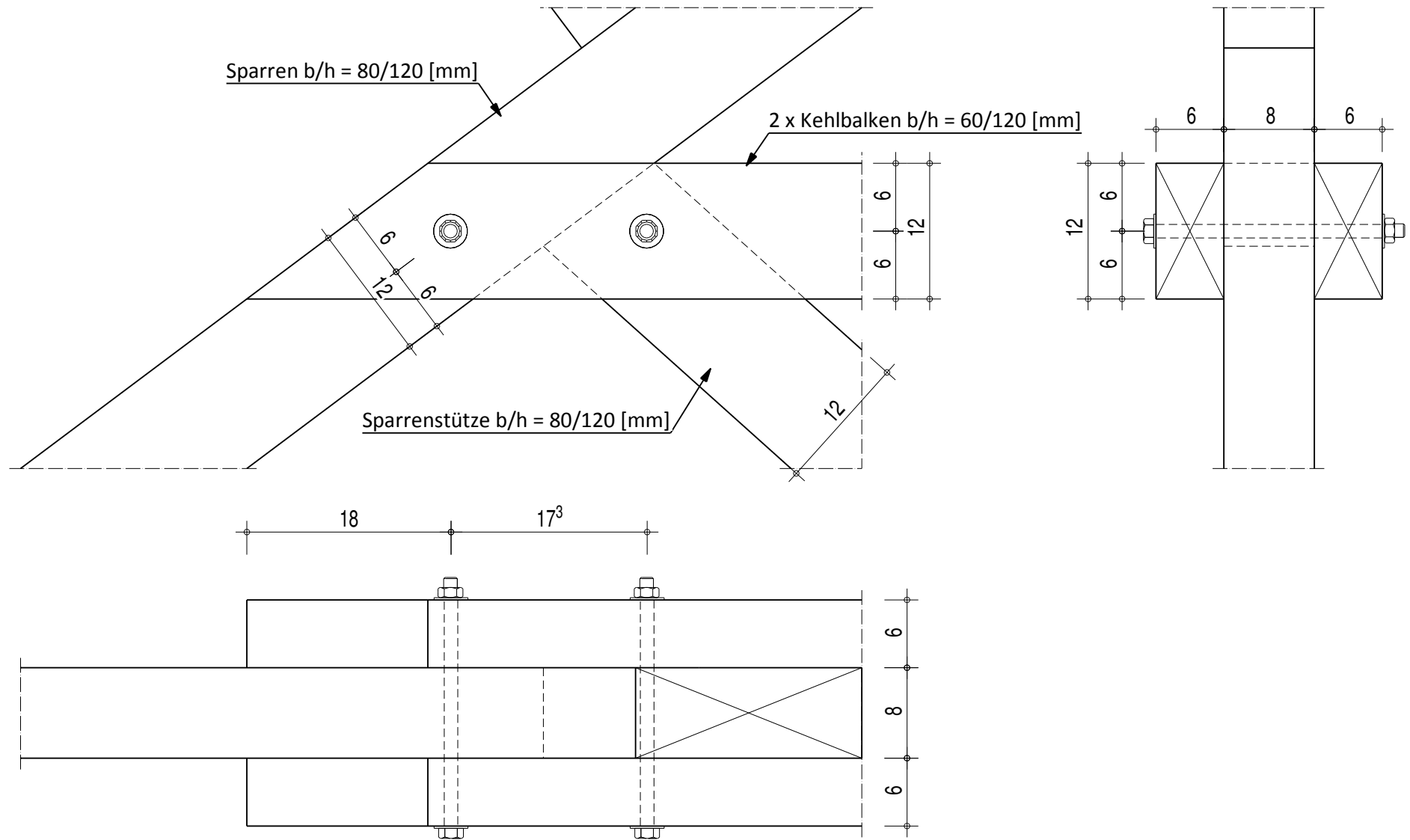

Untergurtanschluss Maßstab 1: 3,33

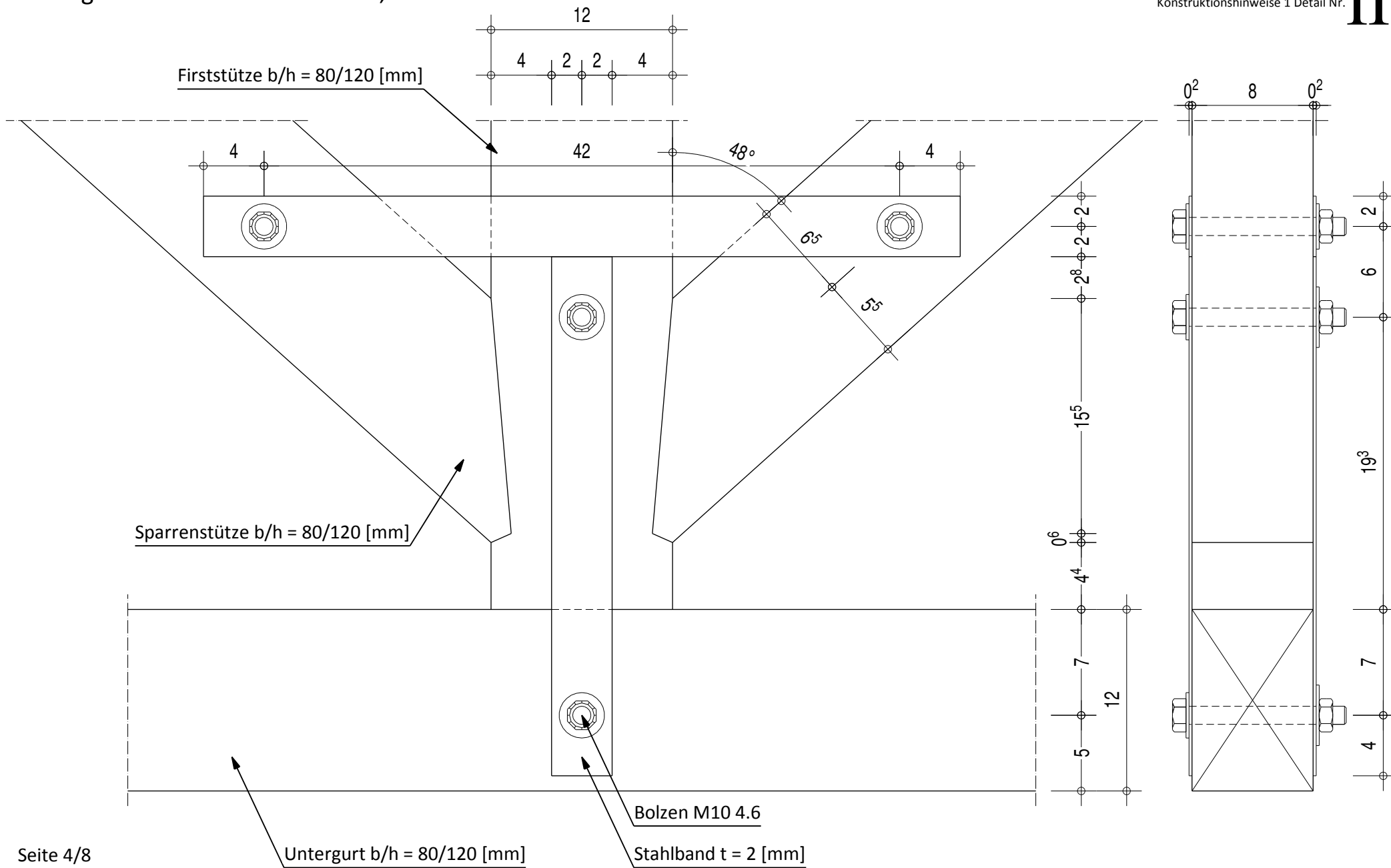

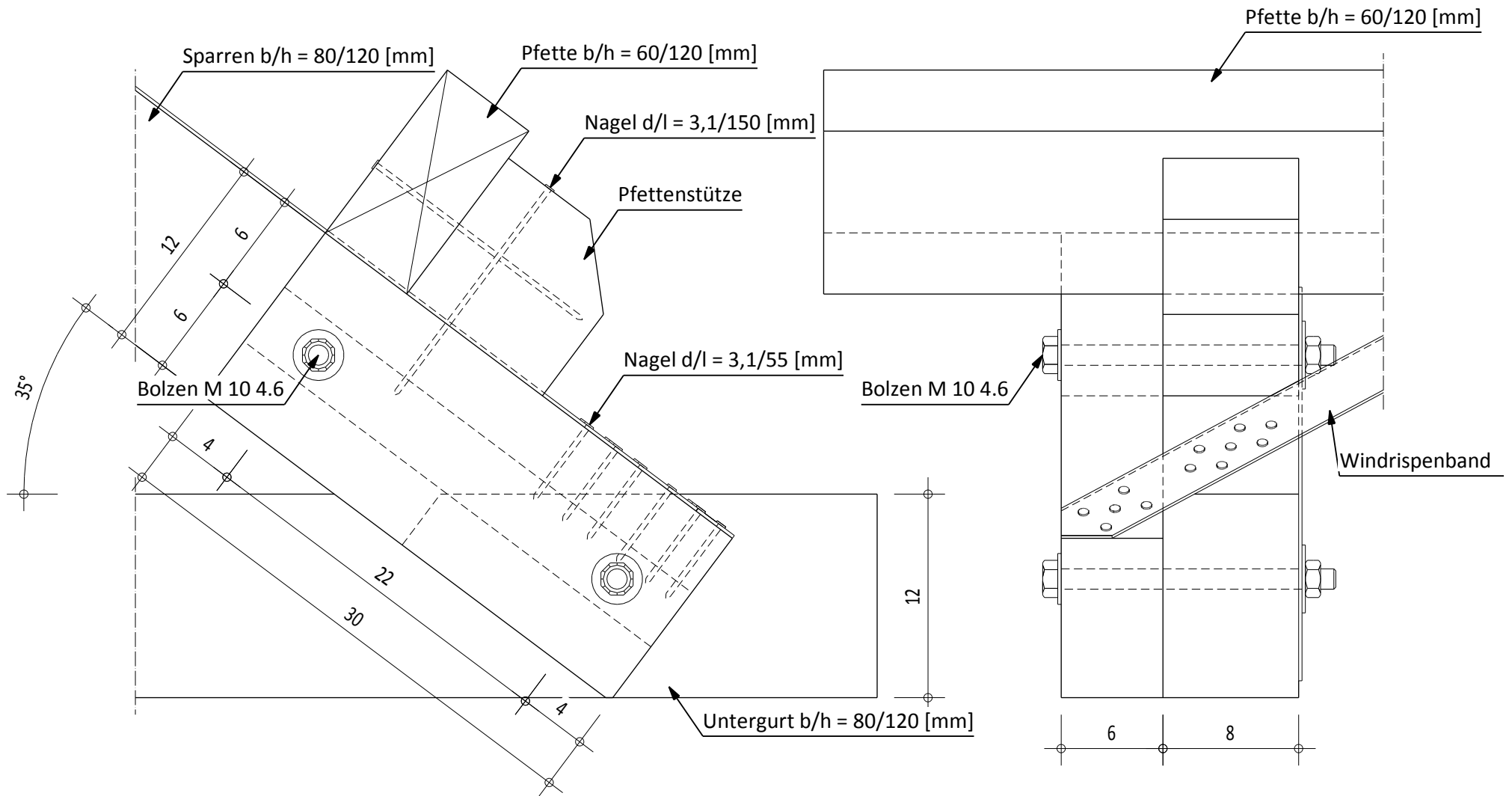

Anschluss und Ausbildung des Ringankers Maßstab 1: 10

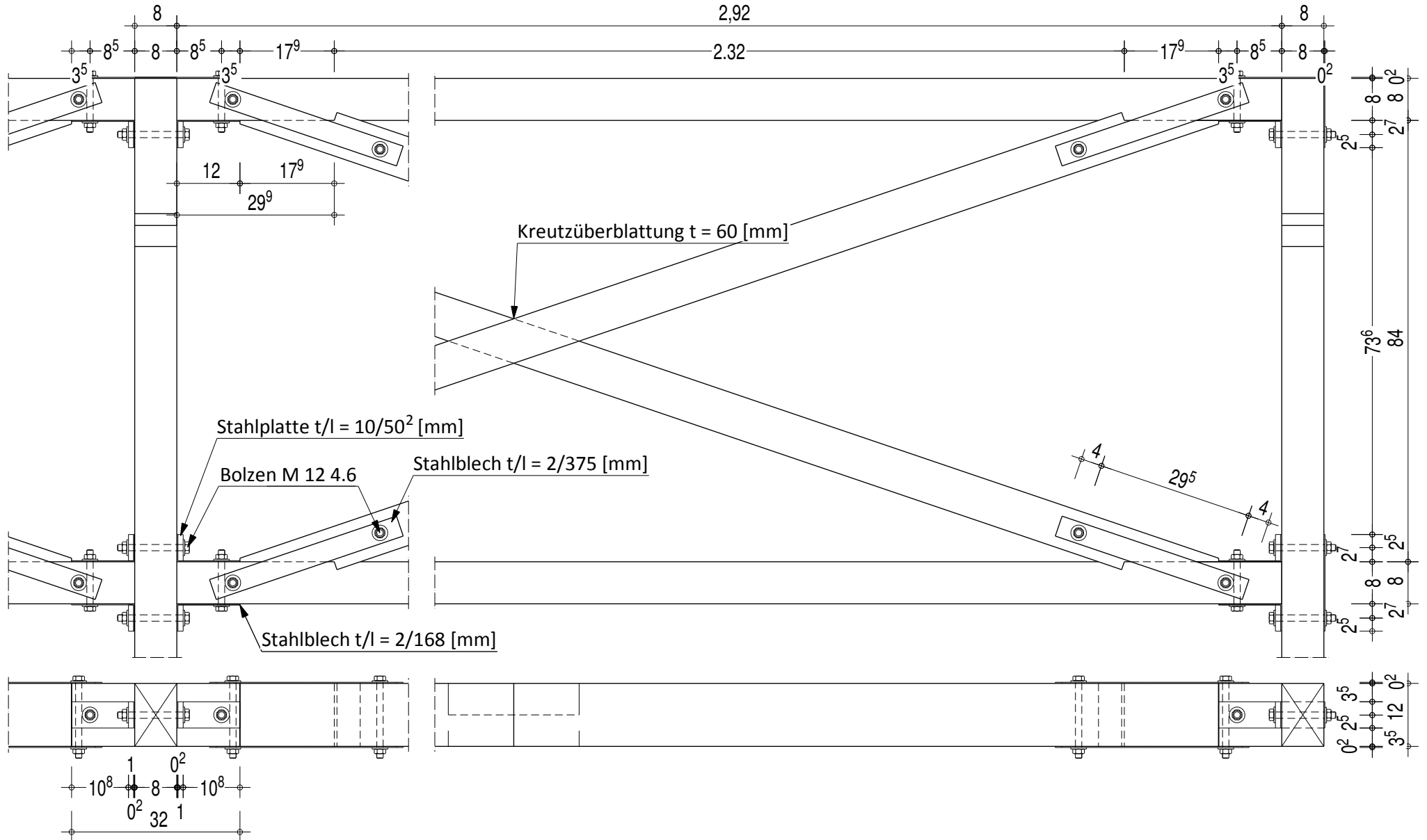

Anschluss der Horizontalaussteifung Maßstab 1: 5

Konstruktionshinweise 1 Detail Nr.

VI

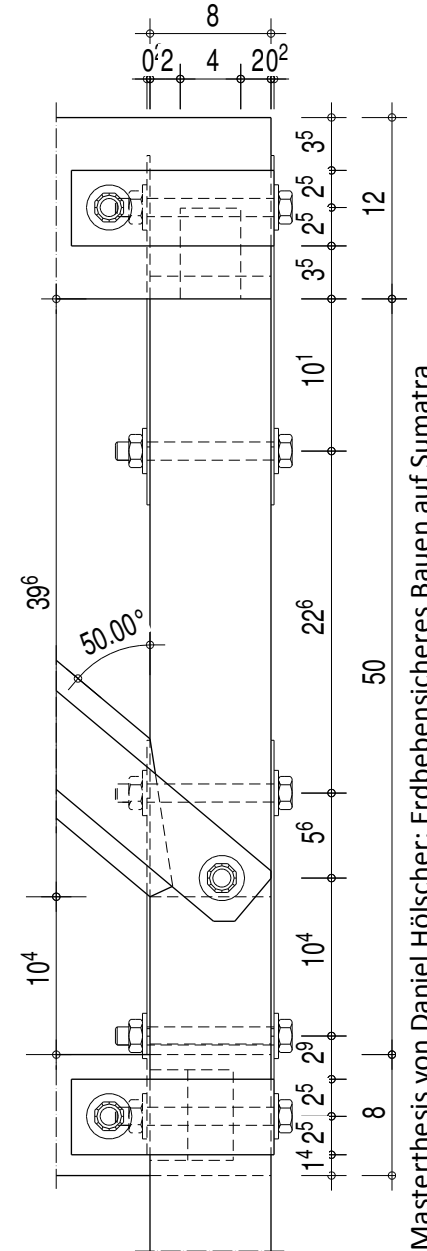
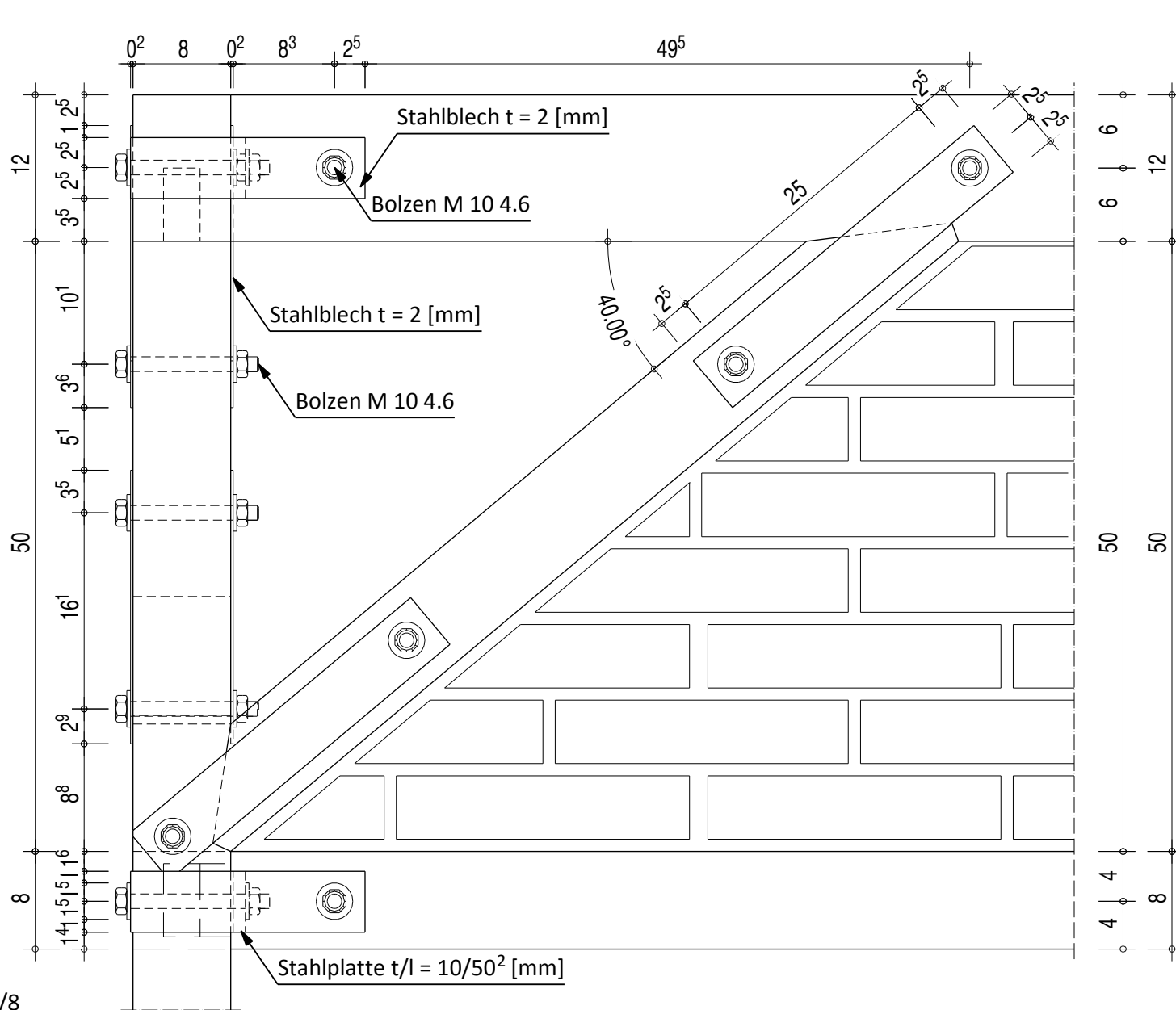

Anschluss und Ausbildung des Ringankers Maßstab 1: 7,5

Konstruktionshinweise 1 Detail Nr.

VII

